



LOWER LEVEL FINISH

PERMITS

1. **Building Permit:** A building permit is required for installing drywall, the new framing of; walls, soffits, lowered ceilings, a fire place enclosure or any alteration of the existing framing.
2. **Plumbing Permit:** A plumbing permit is usually required when finishing a lower level bath room. Additional plumbing work is generally required to complete the drainage and venting system, add additional water lines for the new fixtures and the installation and connection of these systems to the new fixtures.
3. **Mechanical Permit:** A mechanical permit is usually required when finishing a lower level. Additional HVAC work is generally required to add new heat runs and cold air returns for the finished space(s), installing a bath room exhaust fan and duct, installing a new fire place and gas line, adding additional heating or ventilation equipment.
4. **Electrical Permit:** An electrical permit is usually required when finishing a lower level. Most homes with an unfinished basement do not have completed electrical systems and fixtures installed at the time the home was originally built and occupied. The completion of this work will require an electrical permit from the City of Sartell.

Building Permit Applications are available at City Hall or they are available on our website: www.sartellmn.com Completed permit applications and plans can be dropped off at the Sartell City Hall during normal business hours, mailed in or dropped off in the overnight box located in front of the city offices. Normal turnaround time for the permit is 3-5 business days. Upon completion of the review and approval of the plans the applicant will be notified that the permit is ready to be picked up and paid for. Work must not be started until the permit has been approved and picked up from the City.

PERMIT AND PLAN SUBMITTAL

Completed permit applications must be submitted along with two copies of plans showing the following.

- Identify the area(s) intended to be finished.
- Existing and future floor plan or layouts showing the location of new interior walls.
- Dimensions of the finished rooms.
- Rooms must be identified for the intended use (bedroom, bath, family room, storage, etc.).

- Location of existing and new or re-located windows.
- Location of doors.
- Type(s) of construction materials (2x4 studs @ 16" o.c., ½ inch drywall, etc.).

INSPECTIONS

1. Plumbing: After all new drain, waste and vent piping and water lines are installed. A 5 lb pressure test of the new drain, waste and vent piping may be required in accordance with the State Plumbing Code.
2. Mechanical: After all ductwork alterations are completed, bath fan and duct is installed, and fireplace installation is completed.
3. Gas line RI and pressure test: All new gas lines installed must be inspected and pressure tested to 25 psi.
4. Electrical: After all electrical RI work is completed notify the City Electrical Inspector at 320-654-6634.
5. Framing and insulation: Upon completion of all of the previous inspections (if applicable) the framing and insulation will need to be inspected prior to covering.
6. Electrical final: The city electrical inspector must perform a final inspection and will place a tag in the electric panel upon approving the completed work. This must be completed prior to scheduling the final inspection.
7. Final: A final inspection is required prior to legal use or occupancy of the finished space(s). All smoke detectors will need to be installed and operational, egress windows completed for all sleeping rooms, plumbing fixtures installed, heat registers installed and electrical work approved by the City electrical inspector.

Approved plans, inspection card and inspection records from previous inspections must be on site and available for the City inspector at the time of the inspection.

SCHEDULING AN INSPECTION

Inspections are performed Monday thru Friday 8:00 AM to 4:00 PM. Please call 320-258-7317 to schedule your inspection, 24 hours in advance.

GENERAL CODE REQUIREMENTS

Building/Fire

- Smoke detectors must be provided in each sleeping room and in the immediate vicinity outside each sleeping room.
- Smoke detectors must be hard wired, provided with battery back-up and interconnected to all existing hardwired detectors in the home.

- In accordance with Minnesota State Statutes 299F.50 carbon monoxide detectors are required in all single family homes. These detectors must be located within 10 feet of each sleeping room. Carbon monoxide detectors must not be directly wired to a circuit or plugged into an outlet which is controlled by a switch.
- Basements and every sleeping room must have at least one emergency escape and rescue opening (egress window). See the attached egress window information sheet.
- Draft-stopping: Where floor trusses are being enclosed and the enclosed floor/ceiling truss system exceeds 1,000 square feet in area, draft-stopping material must be provided along side of a single truss to sub-divide the area into approximately two equal separate spaces. Draft-stopping material may consist of ½ inch drywall or 3/8 inch or thicker OSB or plywood. See the attached information sheet.
- Fire-blocking: To restrict the movement of flame and hot gases through concealed passages in concealed wood construction fire-blocking must be provided in such areas as; around pipes, at concealed interconnections of open stud and floor spaces and at 10 foot intervals in concealed vertical stud spaces not entirely filled with fiberglass insulation. See the attached fire-blocking diagram sheet.
- The minimum ceiling height in habitable rooms must not be less than 7 feet.
- The area of habitable rooms must not be less than 70 square feet with the least dimension not less than 7 feet horizontally in any direction.
- A handrail must be provided for residential stairs with 4 or more risers.
- The insulation and vapor barrier must be in compliance with the requirements for when the home was originally constructed.
- Rigid foam sheathing installed must be covered with ½ inch sheetrock unless it is tested and approved to be exposed without a thermal barrier cover.

Mechanical

- Enclosing a mechanical room which has power vented, fan assisted or atmospherically vented gas fired appliances may require the installation of combustion or additional combustion air into the mechanical room.
- All bathrooms must be provided with either a mechanical ventilation fan or an operable window. Fan exhaust ducts must be an approved type duct material and the duct must be insulated with a minimum R-4.2 insulation value within 3 feet of the exterior wall termination. The exhaust must not terminate less than 3 feet from a window or fresh air intake.
- Supply branch lines should be provided to all finished habitable spaces with a return duct system for all habitable rooms except for the bathroom.

- The installation of gas fireplaces must be inspected. The exhaust vent and clearances must be installed according to the manufacturer's installation requirements and inspected prior to covering
- All gas lines must be visibly inspected and pressure tested to 25 psi prior to covering. Exposed copper tubing used for gas lines must be properly identified at intervals not exceeding every 5 feet.

Plumbing

- Water closets must have a minimum side clearance of 15 inches from a wall to the center line of the fixture and a minimum front clearance of 24 inches from the front of the water closet to an obstruction.
- Water meters must be accessible.
- Access doors must be provided for bath tub traps and hose bib shut off valves.
- Solvent welding (gluing) of PVC (white plastic) and ABS (black plastic) piping is prohibited.

Radon

- Homes which were built with radon mitigation systems complying with MN Rules 1322 must continue to maintain the integrity of the sub-slab depressurization and venting systems.

If you have an electrical code question please call 320-654-6634. For all other questions regarding any of the information in this handout feel free to call the Building Inspection Department at 320-258-7317.

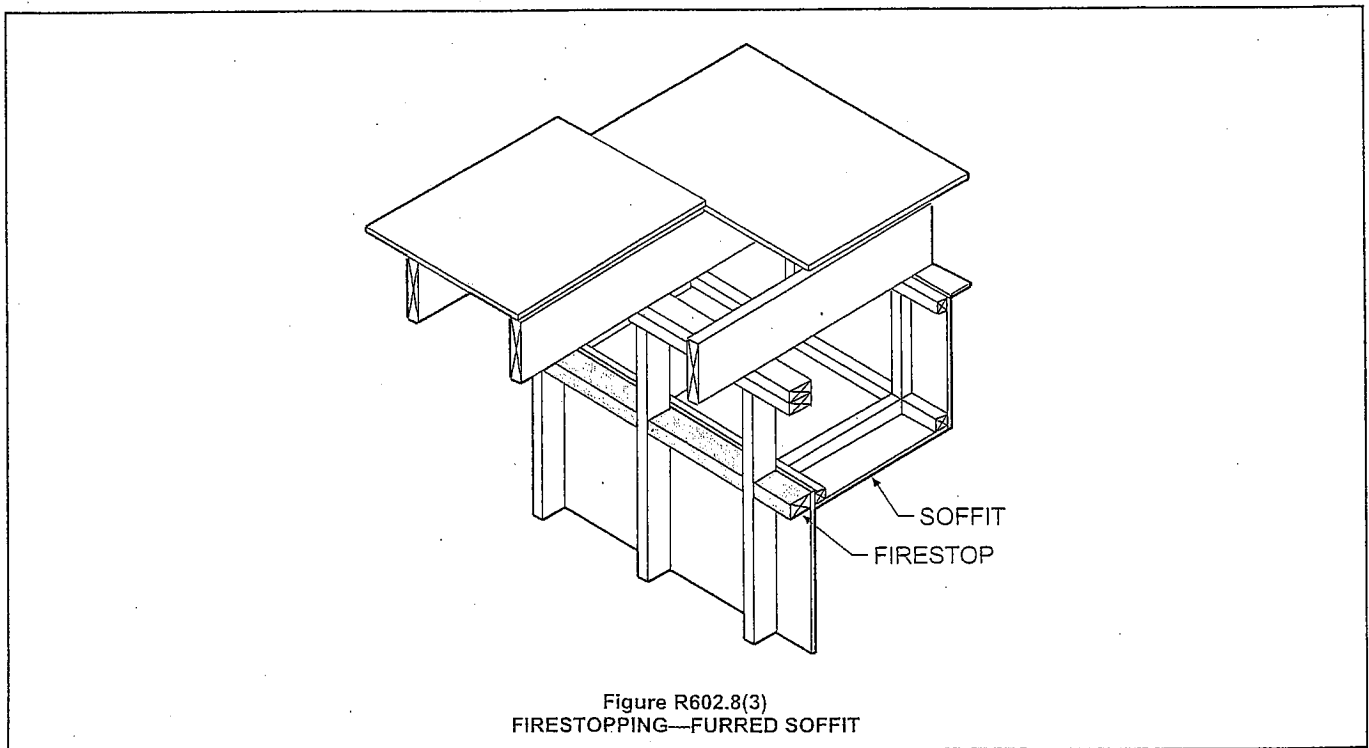
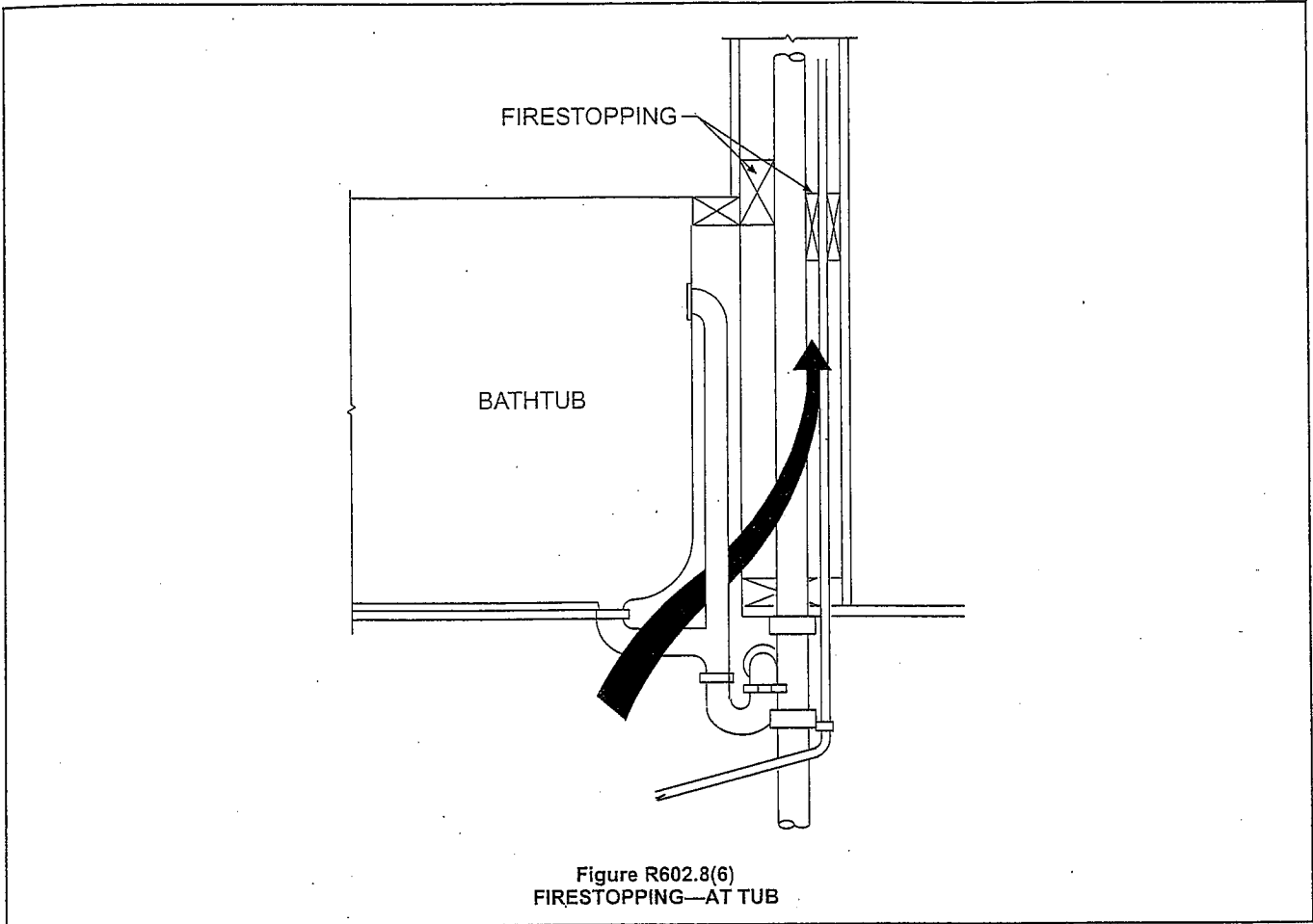

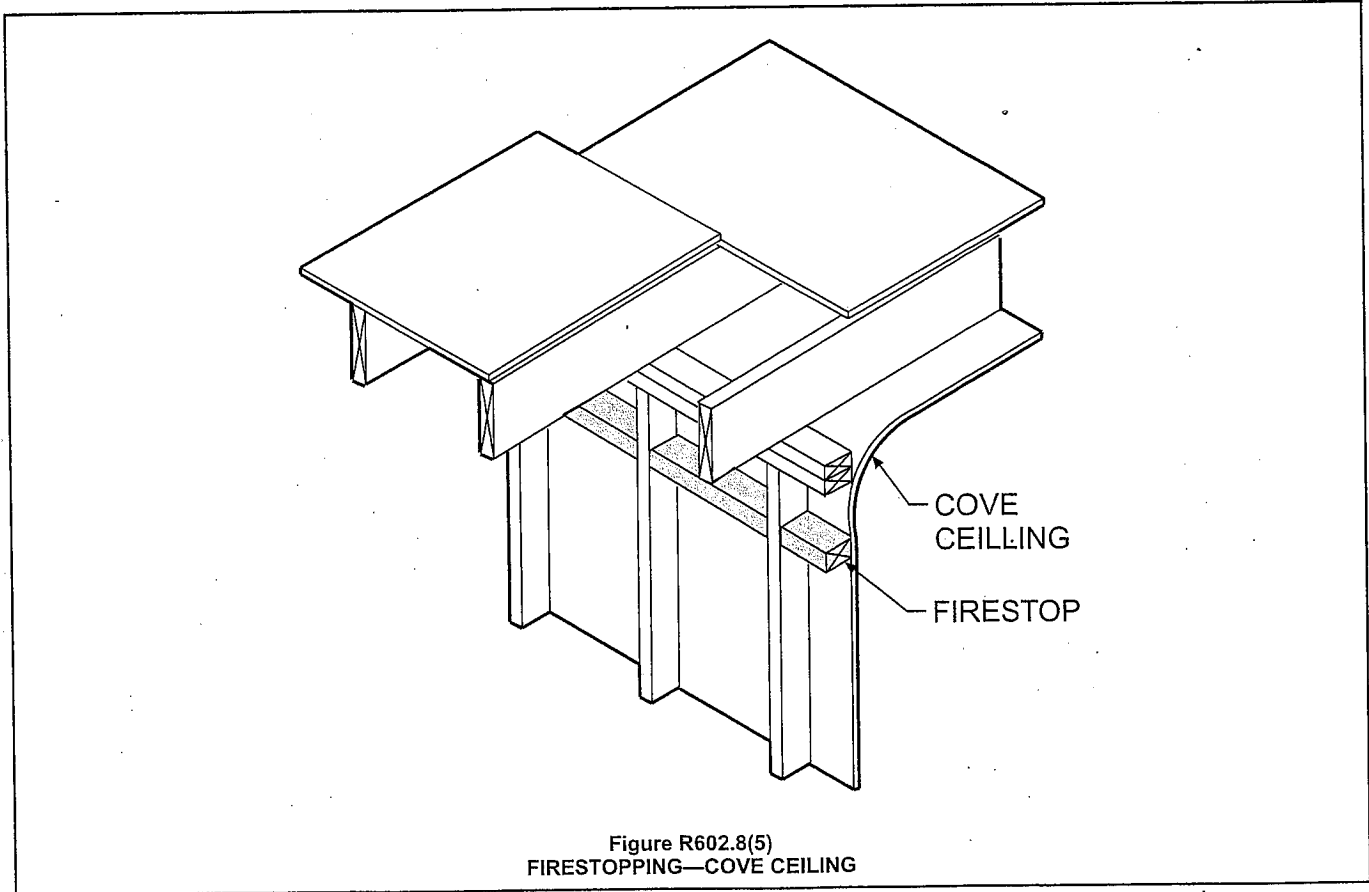
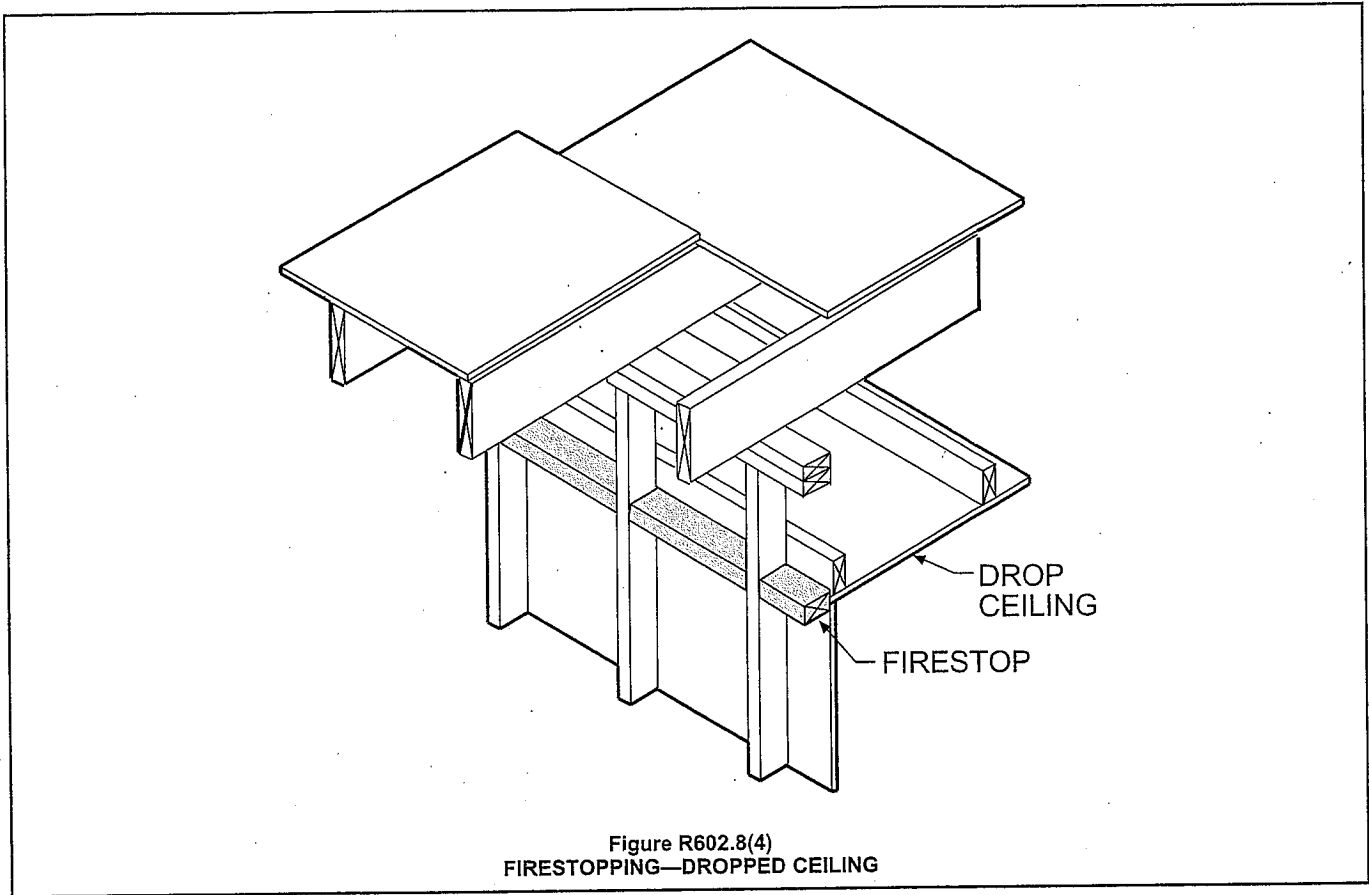

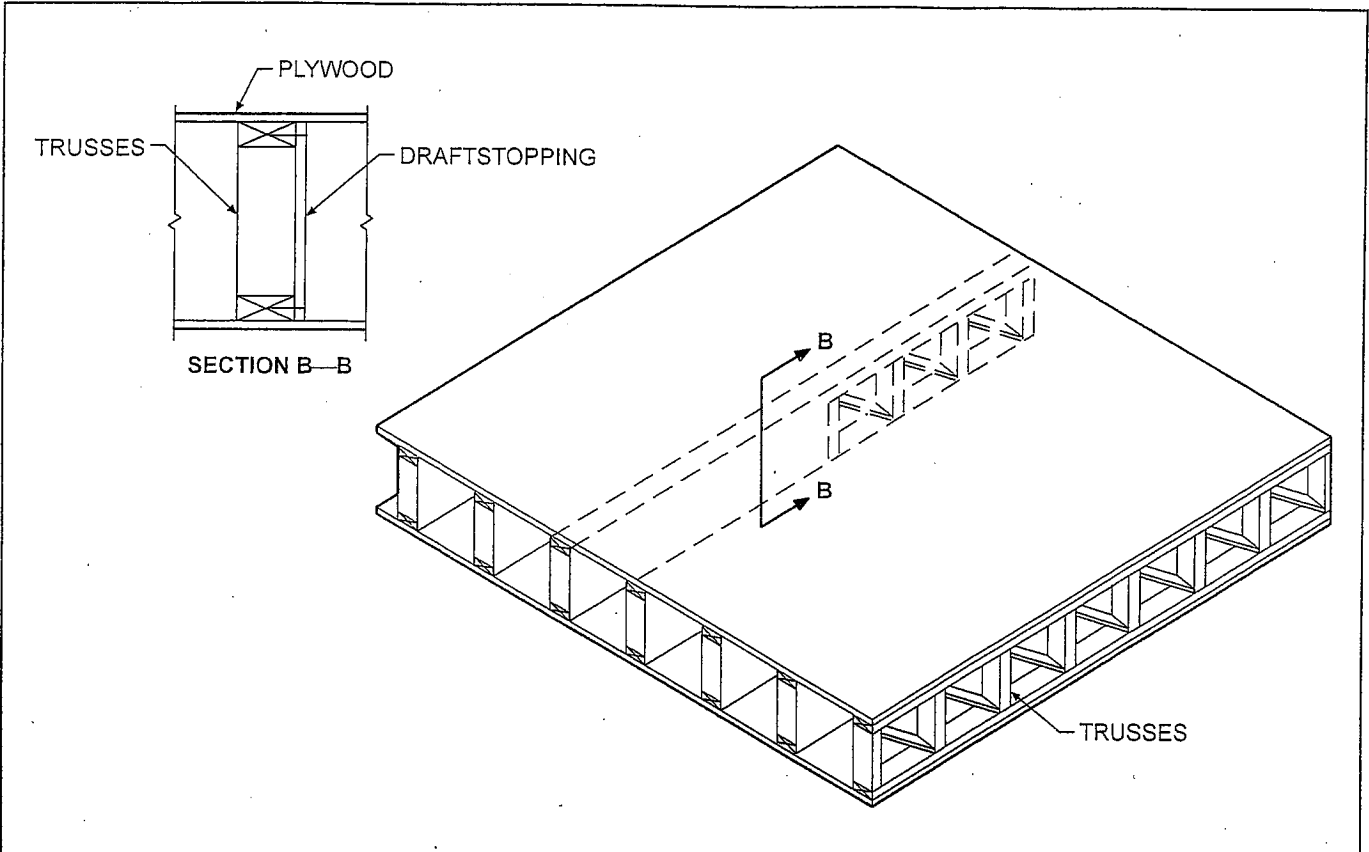

Figure R502.12(2)
DRAFTSTOPPING OF TRUSS-TYPE FLOOR FRAMING

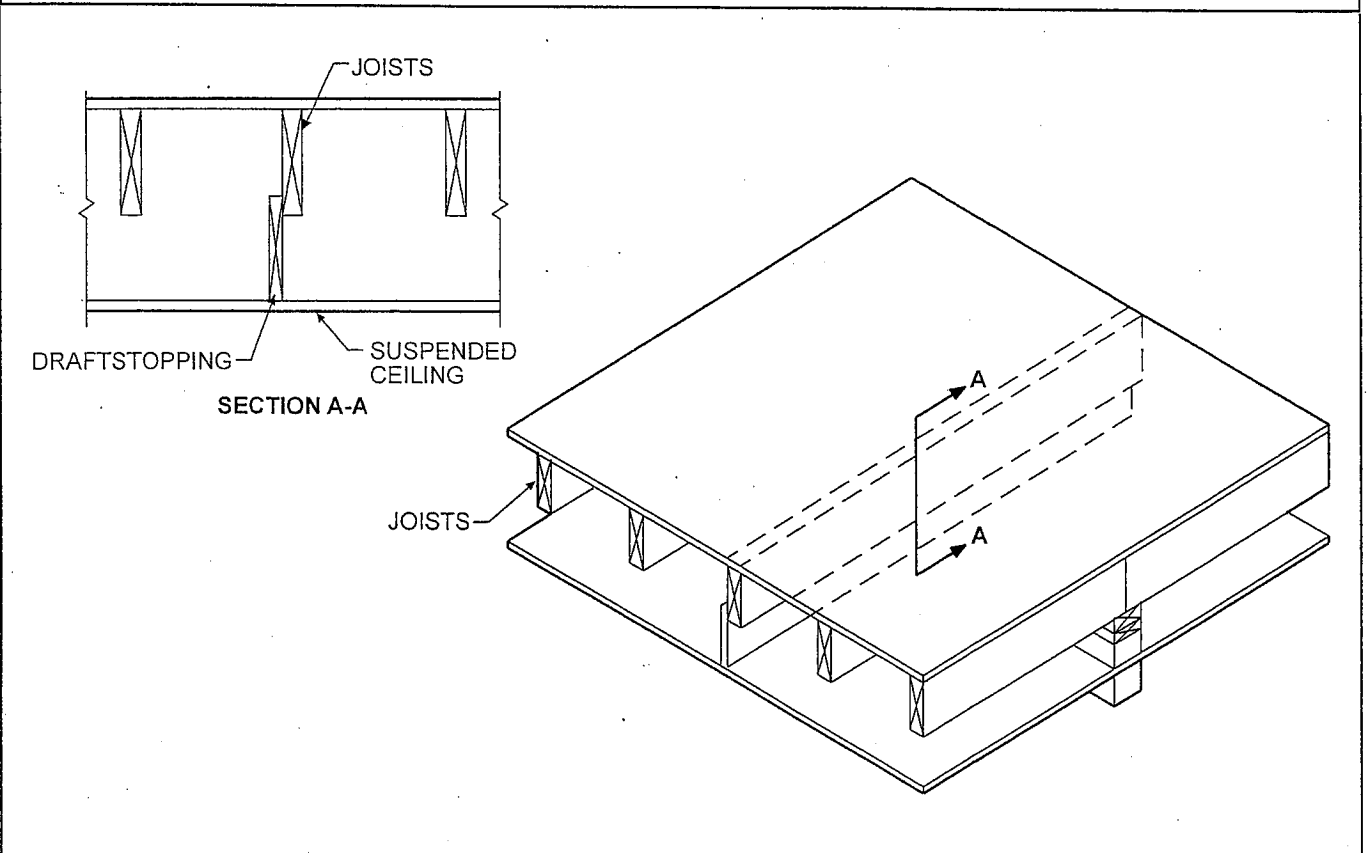

Figure R502.12(1)
DRAFTSTOPPING OF CEILING SUSPENDED UNDER FLOOR FRAMING

EMERGENCY ESCAPE AND RESCUE WINDOW

Required Inspections:

Framing inspection on any window installation that requires the changing of load-bearing framing members or that alters the structural integrity of the exterior wall.

Final inspection is required after the emergency escape window installation is completed. If the window is in a basement or below grade the window well must also be completed

Code Requirements:

Basements with habitable space and every sleeping room shall have at least one openable emergency escape and rescue opening. Windows shall have a sill height of not more than 44 inches above the floor.

All emergency escape and rescue openings shall have a minimum net clear opening of 5.7 sq. ft. The openings shall have a minimum net clear opening of 24 inches height and 20 inches net clear opening in width.

Exception: Grade floor openings shall have a minimum net clear opening of 5 sq. ft.

Grade floor openings is a window or other opening located such that the sill height of the opening is not more than 44 inches above or below the finished ground level adjacent to the opening

